



The Company With Connections®



A BOOT STYLE CONNECTOR FOR SANITARY OR STORMWATER SYSTEMS

Z•LOK STM

Z•LOK STM

The **Z•LOK STM CONNECTOR** was designed by A-LOK Products, Inc. to address the need for a boot style connector for large diameter pipe. This makes it ideally suited for sanitary applications, using smooth wall pipe or corrugated pipe with a factory installed smooth over sleeve and stormwater applications, with corrugated or smooth wall pipe. Available for 6"-102" pipes.

The **Z•LOK STM Pipe to Manhole Connector** is a flexible connector specifically engineered to produce a positive watertight seal for pipes entering precast concrete structures and the structure itself.



Z•LOK STM Connector cast into storm structure.

MATERIAL

The **Z•LOK STM CONNECTOR** is molded from a polyisoprene compound engineered to conform with the requirements of section 4.1.1 of ASTM C-923. Alternative compounds are available for unusual applications upon special order.

All stainless steel hardware is in compliance with section 4.2, "Mechanical Devices" of ASTM C-923.

KEY ADVANTAGES

The **Z•LOK STM CONNECTOR** assures a positive watertight connection and provides up to 15° of omnidirectional deflection and 1.50" of vertical or horizontal movement without loss of seal, providing greater flexibility in the design and installation of pipelines and structures. These design features of the **Z•LOK STM CONNECTOR** prevent infiltration due to shear caused by settlement or ground movement.

Once fastened, immediate backfilling is possible enhancing project safety and overcomes the normal problems encountered with water, running sand and other unstable trench conditions.

When casting the **Z•LOK STM CONNECTOR** into the structure, making it an integral part of the wall, 50% of the opportunity for infiltration is eliminated.

PRODUCT REFERENCES

A.) ASTM C-923

Resilient Connector Between Reinforced Concrete Manholes Structures, Pipe and Laterals.

B.) ASTM C-1478

Resilient Connectors Between Reinforced Concrete Storm Sewers Structures, Pipes and Laterals.

C.) ASTM C-1244

Standard Test Method For Concrete Sewer Manholes by the Negative Air Pressure (Vacuum) Test.

PERFORMANCE STANDARD

The **Z•LOK STM Connector** meets or exceeds all material and test requirements of ASTM C-923-00: "Resilient Connectors Between Reinforced Concrete Manhole Structures, Pipes and Laterals".

See following chart:

RESILIENT TEST REQUIREMENTS OF A.S.T.M. C-923

TEST	RESULTS	ASTM METHOD
Chemical resistance 1 N Sulfuric acid 1 N Hydrochloric Acid	no weight loss no weight loss	at 22°C for 48h
Tensile strength	1200 psi or 8.5 MPa, min	D 412
Elongation at break	350% min.	
Hardness	±5 from mfg's. specified hardness	D 2240 (Shore A durometer)
Accelerated oven-aging	decr. of 15%, max. of original tensile strength, decr. of 20% max. of elongation	D 573, 70±1°C for 7 days
Compression set	decr. of 25%, max. of original deflection	D 395, Method B, at 70°C for 22h
Water absorption	increase of 10%, max. of original by weight	D 471, immerse 0.75 by 2-in. or 19 by 25-mm Specimen in distilled water at 70°C for 48h
Ozone resistance	rating 0	D 1171
Low-temp brittle point	no fracture at -40°C	D 746
Tear resistance	200 lbf/in. or 34 kn/m	D 624, Method B

Copyright ASTM INTERNATIONAL. Reprinted with permission

● PRODUCT SPECIFICATIONS

A flexible pipe to manhole connector shall be used whenever a pipe penetrates into a precast concrete manhole or structure.

The connector shall be the **Z•LOK STM CONNECTOR** as manufactured by **A•LOK PRODUCTS, INC.**, Tullytown, PA, or approved equal.

The design of the connector shall provide a flexible, watertight seal between the pipe and concrete structure. The connector shall assure that a seal is made between:

(1) The connector and the structure wall by casting the connector integrally with the structure wall during the manufacturing process in a manner that it will not pull out during pipe coupling.

(2) The seal between the connector and the pipe shall be made by compressing the connector against the outside circumference of the smooth wall pipe or against the inside walls of the valley of the corrugated pipe by means of a stainless steel take-down clamp.

The connector shall be made from materials that conform to the physical and chemical requirements outlined in Section 4, "Materials and Manufacture" of ASTM C-923 "Standard Specification for Resilient Connectors Between Reinforced Concrete Manhole Structures, Pipes, and Laterals", and the overall design will meet or exceed Section 7, "Test Methods and Requirements" of ASTM C-923, using smooth wall pipe or corrugated pipe with a factory installed smooth over sleeve, and ASTM C-1478 with smooth wall pipe or corrugated pipe.

The connector shall be sized specifically for the type of pipe being used and shall be installed in accordance with the recommendations of the manufacturer.

● FIELD INSTALLATION INSTRUCTIONS



CORRUGATED PIPE

FIELD INSTALLATION

STEP 1:
Z•LOK STM Connector cast into storm structure.



STEP 2:
Pipe is centered through the connector. The Stainless Steel Clamp is centered above the valley of pipe making sure the fastening points are positioned in the two cutout areas of the rubber connector.



STEP 3:
Stainless Steel Clamp is **tightened equally** about the take-up point to 60 in./lbs. This action compresses the rubber against the side walls of the pipe valley and a watertight connection is formed.

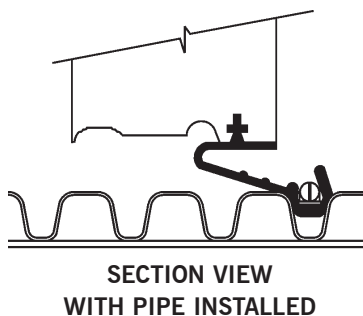

IMPORTANT: After groove of pipe is centered in gasket tighten stainless steel clamp equally to 60 in. lbs. with an A•LOK Torque Wrench.

● PRECAST INSTALLATION INSTRUCTIONS

ONE-PIECE WEDGE KNOCKOUT For 6" Flatwall

Pull connector over one-piece Wedge Knockout Hole Former as shown.

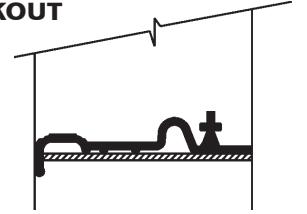

TWO-PIECE MANDREL For 8" Flatwall and above

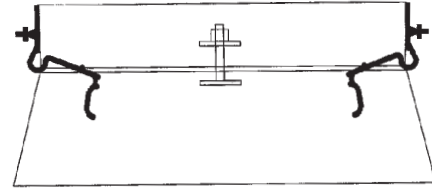

1. Stretch gasket over outside mandrel half, with cut-outs positioned at 3 and 9 o'clock.
2. Force gasket down inside mandrel before installing in form.
3. Use coil nut to tighten gasket and mandrels together.

TWO-PIECE MANDREL For Round Manholes

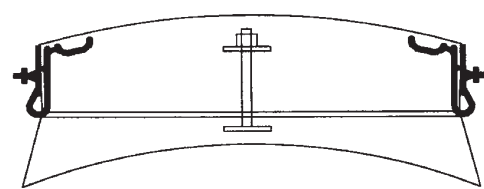

● FIELD INSTALLATION INSTRUCTIONS



SMOOTH WALL PIPE

FIELD INSTALLATION

STEP 1:
Z•LOK STM Connector cast into storm structure.



STEP 2:
Pipe is inserted and centered within the connector to obtain proper mechanical seal.



STEP 3:
Stainless Steel Clamp is tightened equally about the take-up point to 60 in./lbs, insuring a watertight connection. This should be done prior to any pipe deflection or backfilling.

SECTION VIEW WITH PIPE INSTALLED

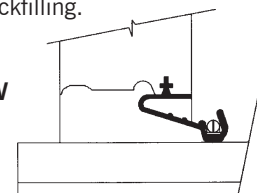

Z-LOK STM CONNECTORS SMOOTH WALL PIPE DATA

FLATWALL CONNECTORS ARE MARKED (S-F) ROUNDWALL CONNECTORS ARE MARKED (S-R)
SMOOTHWALL Z-LOK STM CONNECTORS DO NOT HAVE NOTCHES AT 3 & 9 TO TIGHTEN DOWN CLAMPS

Z-LOK STM PART #	MIN. PIPE O.D.	MAX. PIPE O.D.	Z-LOK STM MANDREL PART#	Z-LOK STM CLAMP PART#
ZS-8016-S-F ZS-8016-S-R	14.00"	15.00"	SM-8016-F SM-8016-R	CL-128 + CL-188
ZS-8019-S-F ZS-8019-S-R	16.00"	17.00"	SM-8019-F SM-8019-R	CL-128 + CL-188
ZS-8020-S-F ZS-8020-S-R	17.00"	18.00"	SM-8020-F SM-8020-R	CL-128 + CL-188
ZS-8021-S-F ZS-8021-S-R	18.00"	19.00"	SM-8021-F SM-8021-R	CL-128 + CL-188
ZS-8022-S-F ZS-8022-S-R	19.00"	20.00"	SM-8022-F SM-8022-R	CL-128 + CL-188
ZS-8023-S-F ZS-8023-S-R	20.00"	21.00"	SM-8023-F SM-8023-R	CL-088 + CL-248
ZS-8024-S-F ZS-8024-S-R	21.00"	22.00"	SM-8024-F SM-8024-R	CL-088 + CL-248
ZS-8025-S-F ZS-8025-S-R	22.00"	23.00"	SM-8025-F SM-8025-R	CL-128 + CL-248
ZS-8026-S-F ZS-8026-S-R	23.00"	24.00"	SM-8026-F SM-8026-R	CL-188 + CL-248
ZS-8027-S-F ZS-8027-S-R	24.00"	25.00"	SM-8027-F SM-8027-R	CL-188 + CL-248
ZS-8028-S-F ZS-8028-S-R	25.00"	26.00"	SM-8028-F SM-8028-R	CL-248 (2)*
ZS-8029-S-F ZS-8029-S-R	26.00"	27.00"	SM-8029-F SM-8029-R	CL-248 (2)*
ZS-8030-S-F ZS-8030-S-R	27.00"	28.00"	SM-8030-F SM-8030-R	CL-248 (2)*
ZS-8031-S-F ZS-8031-S-R	28.00"	29.00"	SM-8031-F SM-8031-R	CL-248 (2)*
ZS-8032-S-F ZS-8032-S-R	29.00"	30.00"	SM-8032-F SM-8032-R	CL-248 (2)*
ZS-8033-S-F ZS-8033-S-R	30.00"	31.00"	SM-8033-F SM-8033-R	CL-248 (2)*
ZS-8034-S-F ZS-8034-S-R	31.00"	32.00"	SM-8034-F SM-8034-R	CL-040 + CL-248 (2)*
ZS-8035-S-F ZS-8035-S-R	32.00"	33.00"	SM-8035-F SM-8035-R	CL-040 + CL-248 (2)*
ZS-8036-S-F ZS-8036-S-R	33.00"	34.00"	SM-8036-F SM-8036-R	CL-040 + CL-248 (2)*
ZS-8037-S-F ZS-8037-S-R	34.00"	35.00"	SM-8037-F SM-8037-R	CL-088 + CL-248 (2)*
ZS-8038-S-F ZS-8038-S-R	35.00"	36.00"	SM-8038-F SM-8038-R	CL-088 + CL-248 (2)*
ZS-8039-S-F ZS-8039-S-R	36.00"	37.00"	SM-8039-F SM-8039-R	CL-128 + CL-248 (2)*
ZS-8040-S-F ZS-8040-S-R	37.00"	38.00"	SM-8040-F SM-8040-R	CL-128 + CL-248 (2)*
ZS-8041-S-F ZS-8041-S-R	38.00"	39.00"	SM-8041-F SM-8041-R	CL-128 + CL-248 (2)*
ZS-8042-S-F ZS-8042-S-R	39.00"	40.00"	SM-8042-F SM-8042-R	CL-128 + CL-248 (2)*
ZS-8043-S-F ZS-8043-S-R	40.00"	41.00"	SM-8043-F SM-8043-R	CL-188 + CL-248 (2)*
ZS-8044-S-F ZS-8044-S-R	41.00"	42.00"	SM-8044-F SM-8044-R	CL-188 + CL-248 (2)*
ZS-8045-S-F ZS-8045-S-R	42.00"	43.00"	SM-8045-F SM-8045-R	CL-188 + CL-248 (2)*
ZS-8046-S-F ZS-8046-S-R	43.00"	44.00"	SM-8046-F SM-8046-R	CL-248 (3)*
ZS-8047-S-F ZS-8047-S-R	44.00"	45.00"	SM-8047-F SM-8047-R	CL-248 (3)*
ZS-8048-S-F ZS-8048-S-R	45.00"	46.00"	SM-8048-F SM-8048-R	CL-248 (3)*

NOTE: 2 PIECE MANDRELS MUST BE USED FOR FLATWALL STRUCTURES ABOVE 6" AND ALL ROUNDWALL STRUCTURES.
Z-LOK STM SMOOTHWALL CONNECTORS NEED BETWEEN 1-3 CLAMPS DEPENDING ON SIZE. SEE (*)

ANY QUESTIONS REGARDING Z-LOK STM CONNECTOR INSTALLATION, PLEASE CALL 1-800-822-2565

Z-LOK STM CONNECTORS

CORRUGATED PIPE DATA

FLATWALL CONNECTORS ARE MARKED (C-F) ROUNDWALL CONNECTORS ARE MARKED (C-R)
 CORRUGATED Z-LOK STM CONNECTORS HAVE NOTCHES LOCATED AT 3 & 9 FOR TAKE-DOWN CLAMP ADJUSTMENT.

Z-LOK STM PART #	PIPE SIZE	MAX. O.D.	Z-LOK STM MANDREL PART#	Z-LOK STM CLAMP SIZE
ZS-8016-C-F	12" CPP	15.00"	SM-8016-F	CL-EV12L
ZS-8016-C-R			SM-8016-R	
ZS-8019-C-F	15" CPP	17.75"	SM-8019-F	CL-EV15-18L
ZS-8019-C-R			SM-8019-R	
ZS-8022-C-F	18" CPP	21.47"	SM-8022-F	CL-EV15-18L
ZS-8022-C-R			SM-8022-R	
ZS-8029-C-F	24" CPP	27.80"	SM-8029-F	CL-EV24L
ZS-8029-C-R			SM-8029-R	
ZS-8031-C-F	24" HANCOR ONLY	28.40"	SM-8031-F	CL-EV24H
ZS-8031-C-R			SM-8031-R	
ZS-8039-C-F	30" CPP	35.50"	SM-8039-F	CL-EV30H
ZS-8039SCR			SM-8039-R	
ZS-8045-C-F	36" CPP	41.75"	SM-8045-F	CL-EV36H
ZS-8045-C-R			SM-8045-R	

CORRUGATED POLYETHYLENE PIPE (CPP) NEEDS THE EV CLAMP DESIGN.

NOTE: NEED TO INDICATE WHEN ORDERING IF GASKETS ARE FOR ROUND OR FLATWALL

EXAMPLE: ZS-XXXX-C-F = CORRUGATED FOR FLATWALL STRUCTURES
 ZS-XXXX-C-R = CORRUGATED FOR ROUND STRUCTURES

NOTE: ZS-8031 WOULD BE FOR 24" HANCOR PIPE BECAUSE OF THE LARGER VALLEY ON THE PIPE.

COMPONENT IDENTIFICATION FOR Z-LOK STM CONNECTORS

Z-LOK STM PART#	PIPE SIZE	MAX. O.D.	Z-LOK STM MANDREL PART #	Z-LOK STM CLAMP SIZE
ZS-8016-C-F	12" CPP	15.00"	SM-8016-F	CL-EV12L
ZS-8016-C-R			SM-8016-R	
ZS-8019-C-F	15" CPP	17.75"	SM-8019-F	CL-EV15-18L
ZS-8019-C-R			SM-8019-R	
ZS-8022-C-F	18" CPP	21.47"	SM-8022-F	CL-EV15-18L
ZS-8022-C-R			SM-8022-R	
ZS-8029-C-F	24" CPP	27.80"	SM-8029-F	CL-EV24L
ZS-8029-C-R			SM-8029-R	
ZS-8031-C-F	24" HANCOR ONLY	28.40"	SM-8031-F	CL-EV24H
ZS-8031-C-R			SM-8031-R	
ZS-8039-C-F	30" CPP	35.50"	SM-8039-F	CL-EV30H
ZS-8039-C-R			SM-8039-R	
ZS-8045-C-F	36" CPP	41.75"	SM-8045-F	CL-EV36H
ZS-8045-C-R			SM-8045-R	

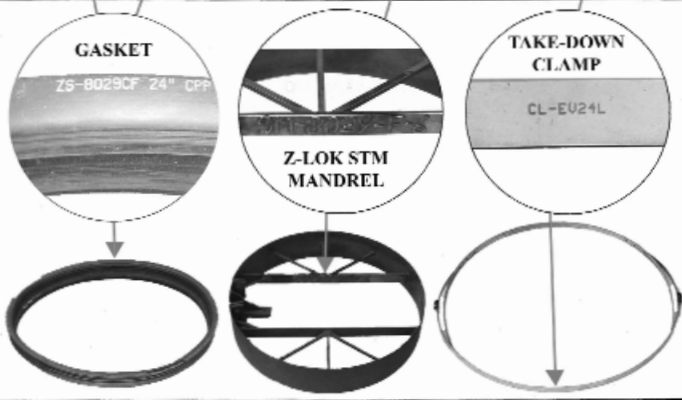

Z-LOK STM PROFILE COMPARISON



Smooth Wall Pipe

MANHOLE DIA.	MAX. O.D. PIPE
48" DIA. 5" WALL	28 IN.
60" DIA. 6" WALL	30 IN.
72" DIA. 7" WALL	37 IN.
84" DIA. 8" WALL	44 IN.
96" DIA. 9" WALL	51 IN.

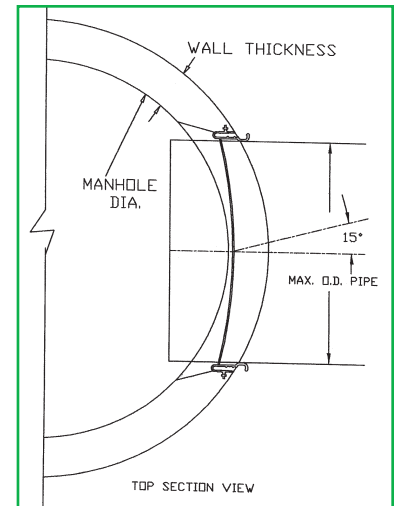

Corrugated Pipe

MANHOLE DIA.	MAX. O.D. PIPE
48" DIA. 5" WALL	22 IN.
60" DIA. 6" WALL	30 IN.
72" DIA. 7" WALL	37 IN.
84" DIA. 8" WALL	42 IN.

