

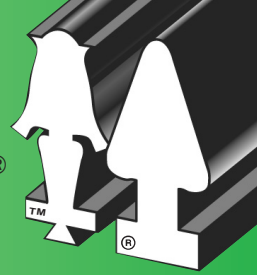

The Company With Connections®



LIFTING SYSTEM FOR PRECAST STRUCTURES

# KEY-LOK

## ● A-LOK KEY-LOK™



Certified KEY-LOK™ lift bar with Choker chains for lifting cones.

The KEY-LOK™ LIFTING SYSTEM is designed to provide a safe, watertight and economical means of handling precast concrete structures.

The polypropylene lift pin insert is installed during the manufacturing process and becomes an integral part of the structure with a predetermined thickness of concrete forming a barrier to prevent infiltration into the structure.



The lift pin and lift bar hardware is designed to provide a safe and durable means of handling precast concrete structures.

## ● MATERIAL

The KEY-LOK™ Lift Pin Insert is molded from a copolymer polypropylene compound.

The KEY-LOK™ Lift Pin and Lift Bar hardware is designed and made to meet The Code of Federal Regulations: 29 CFR 1926.704(d) and CFR 1926.251(a)(4) for lifting devices. Quality and reliability is assured through testing each device.

## ● KEY ADVANTAGES

The KEY-LOK™ LIFT INSERT is designed with a key slot to prevent rotation in the mold and to provide easy form removal in both wet cast and dry cast methods of production.

The insert forms a precise cavity to accept the keyed lifting pins. This assures minimum movement of the lifting device during handling.

The shape of the insert locks the lifting device into the cavity as lifting tension is applied. The KEY-LOK™ Lift Pins rotate 90° for removal.

The KEY-LOK™ Lift Pin Insert eliminates the necessity of a cold joint in patching the lift hole allowing immediate backfilling of the structure, enhancing project quality and safety.

The use of a KEY-LOK™ Manhole Lift Bar assures that the Key-LOK Lift Pins stay perpendicular to the manhole wall while lifting.

## ● PRODUCT REFERENCES

### A.) ASTM-C-478

Standard Specification for Precast Reinforced Concrete Manhole Sections.

### B.) FEDERAL REGULATION CODES

29 CFR 1926.704(c) and (d)  
29 CFR 1926.251 (a) (4)

## ● PERFORMANCE STANDARD

The A-LOK® Lift Pin's working load is in observance of Federal Regulation codes 29 CFR 1926. 704 (d) and 29 CFR 1926.251 (a) (4).

## ● PART 6 • DIMENSIONAL DATA

Listed below are the proof of design testing results:

Wall Thickness (Inches)	Insert No.	Working Load/Pin (lb.)
5	1095	4500
4-1/2	1096	3400
6	1097	6500
3-1/2	1098	2000

NOTE: The concrete had a 28 day compressive strength of 4,000 PSI. The U-shaped reinforcement in the following illustration, is required to obtain the above proof of design.

# PRODUCTION INSTRUCTIONS

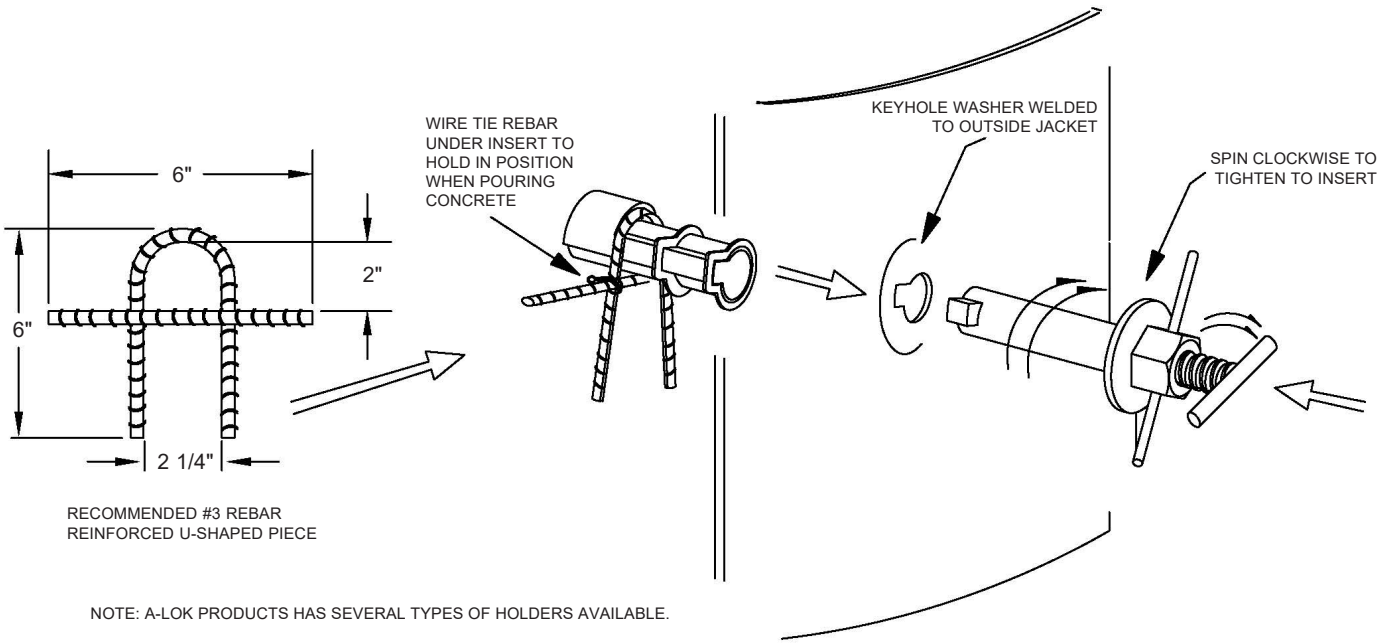

# MANHOLE LIFT INSTRUCTIONS

The A•LOK® Lift Bar is designed to provide a safe and economical means of handling pre-cast manholes and other concrete structures. As lifting tension is applied, the lift pins rotate 90 degrees in the A•LOK® Insert to a locked position for safe handling. A•LOK® meets OSHA 5:1 safety factor. PLEASE NOTE: Lift Bar, pins and chains should be vertical with manhole when lifting.

TECHNICAL DATA CHART:

LIFT BAR	LIFT INSERTS	WORKING LOAD (lb.)
48" Ø 5" WALL	1095 (2)	9000
60" Ø 6" WALL	1097 (2)	13,000

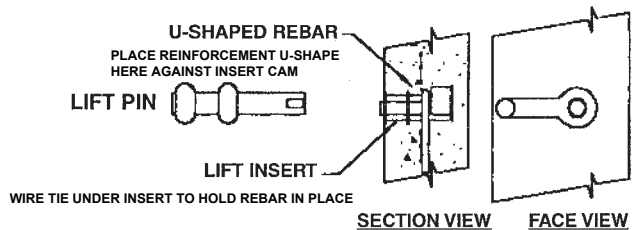
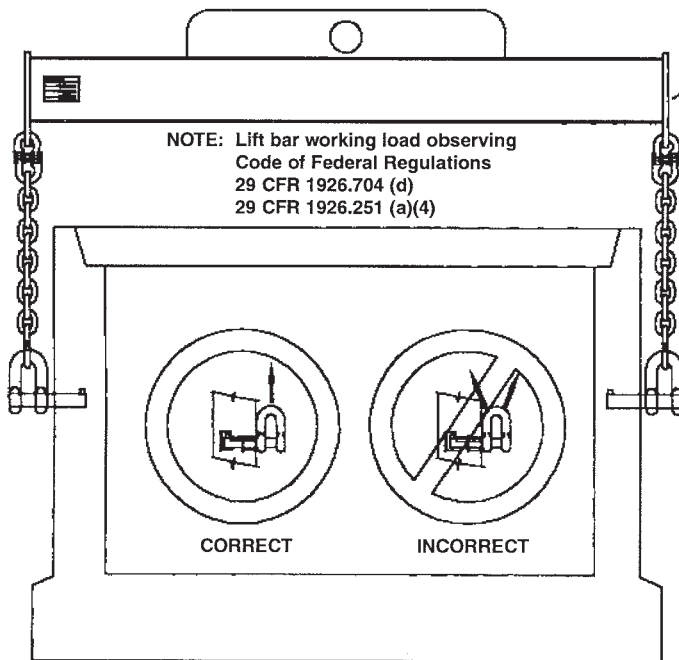

TECHNICAL DATA CHART:

LIFT PIN No.	WORKING LOAD/PIN (lb.)
1095	4500
1096	3400
1097	6500
1098	2000

NOTE: Lift bar working load observing Code of Federal Regulations 29 CFR 1926.704 (d) 29 CFR 1926.251 (a)(4)

NOTE: PLACEMENT OF INSERT SHOULD BE 1.5" OVER CENTER OF STRUCTURE

**WARNING:** Serious harm or death may result from safety hazards caused by improper use and installation of this product. Use of this product in applications other than those stated should first be carefully tested prior to general production use. Testing must accurately represent intended use, with full consideration to all field conditions and factors of safety. The safe working load of this product should always be observed. PLEASE NOTE: A LIFT BAR SHOWING ANY SIGNS OF DEFORMATION OR WEAKNESS SHOULD BE DISCARDED.

## MANHOLE LIFT BAR

The A•LOK Lift Bar is designed to provide a safe and economical means of handling precast manholes and other concrete structures. As lifting tension is applied the lift pins rotates 90° in the A•LOK insert to a locked position for safe handling. A•LOK meets OSHA 5:1 safety factor.

**PLEASE NOTE:** Liftbar pins and chains should be vertical with manhole when lifting.

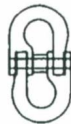

**NOTE:** 3/4" HAMMER-LOK  
 AND CHOKER CHAIN FOR CONES (Optional)

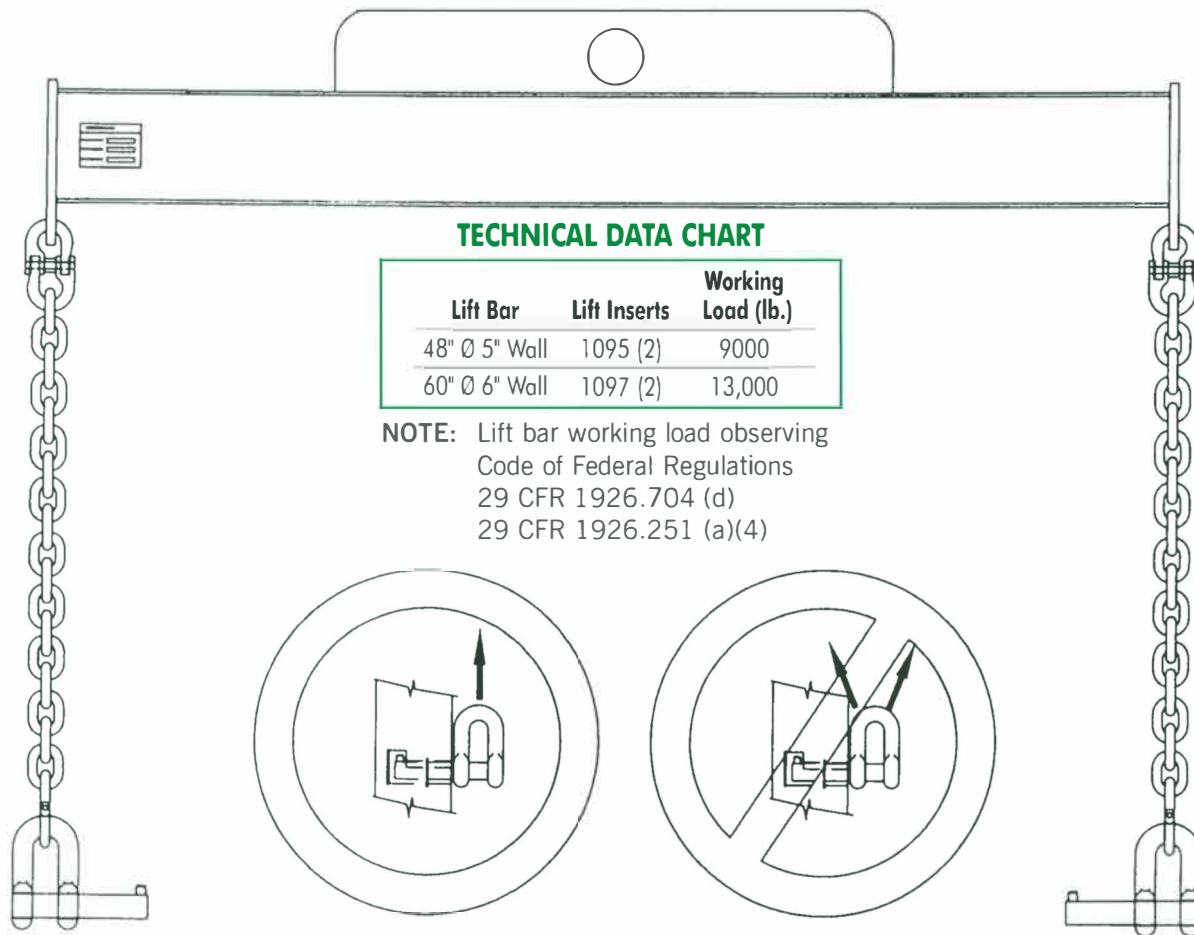

### TECHNICAL DATA CHART

Lift Bar	Lift Inserts	Working Load (lb.)
48" Ø 5" Wall	1095 (2)	9000
60" Ø 6" Wall	1097 (2)	13,000

**NOTE:** Lift bar working load observing Code of Federal Regulations 29 CFR 1926.704 (d) 29 CFR 1926.251 (a)(4)

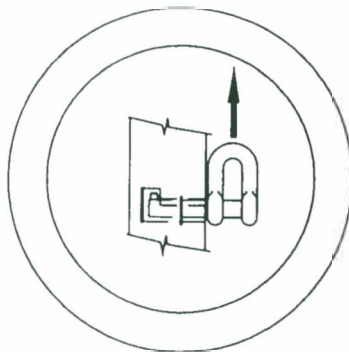

**CORRECT**

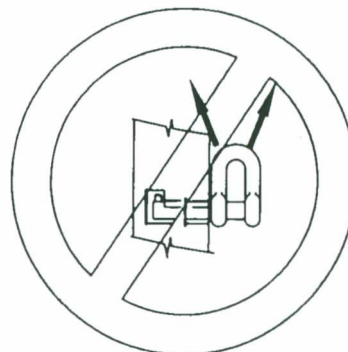

**INCORRECT**

### WARNING

Serious harm or death may result from safety hazards caused by improper use or installation of this product.

Use of this product in applications other than those stated should be first carefully tested prior to general production use. Testing must accurately represent intended use, with full consideration to all field conditions and factors of safety. The safe working load of this product should always be observed.

**PLEASE NOTE:** A LIFT BAR SHOWING ANY SIGNS OF DEFORMATION OR WEAKNESS SHOULD BE DISCARDED.

## ● Key-LOK™ Lift Insert Holders

for placement of all size Key-LOK™ Lift Inserts to specifically accommodate Key-LOK™ Lift Pins



### Universal Lift Insert Holders

**LH-109X-UNIV**

- Works with all size wet and dry cast inserts
- Installed with Key-LOK™ Washers (shown to the right)

**LH-KWASHER**  
Key-LOK™ Washer



### Coil Style Lift Insert Holders

**LH-1095-C, LH-1096-C, LH-1097-C, LH-1098-C**

- Works with all size wet and dry cast inserts
- Installed with Key-LOK™ Washers (shown to the right)

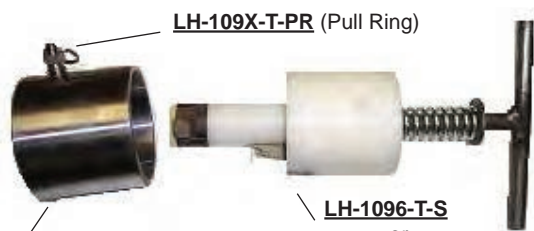

### Spring-Loaded Lift Pin Holders

**LH-1095-T & LH-1096-T (kit)**

- Works with all size wet and dry cast inserts
- Steel collar is welded to jacket

**LH-109X-T-C** (Steel Collar)

**LH-1096-T-S**  
or  
**LH-1095-T-S**

(Tube Holder Shaft)



### Cam-LOK™ Lift Insert Holders

**LH-1095-BR**

Cam-LOK™ Lift Insert Holder and Steel Collar welded to jacket with centered or offset holding pin with tether

(Steel Collar)  
**LH-109X-BR-C** (center)  
or  
**LH-109X-BR-C-O** (offset)

**LH-109X-BR-P**  
(Cam-LOK Lift Insert)

(Lift Insert Holder)  
**LH-109X-BR-I** (center)  
or  
**LH-109X-BR-I-O** (offset)



**LH-1099-U-P**  
(Urethane Lift Pin Holder Insert)



**LH-1099-U-S**  
(Installation  
Pin T-Bolt)

### Urethane Lift Insert Holders

**LH-1099-U** (kit)

- Economical method to place Key-LOK™ Lift Inserts
- Requires 3/8" hole





● **Key-LOK Lift Insert Capacity**

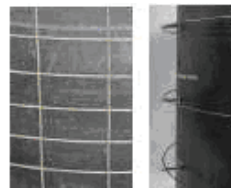

STANDARD  
REINFORCEMENT

U-SHAPE  
REINFORCEMENT

**LI-1098B**  
3-1/2" Wall

**1,200**  
POUNDS / INSERT

**2,000**  
POUNDS / INSERT

**LI-1096B**  
4-1/2" Wall

**2,000**  
POUNDS / INSERT

**3,400**  
POUNDS / INSERT

**LI-1095A**  
Wet Cast 5" Wall  
**LI-1095B**  
Dry Cast 5" Wall

**3,000**  
POUNDS / INSERT

**4,500**  
POUNDS / INSERT

**LI-1097A**  
Wet Cast 6" or 7" Wall  
**LI-1097B**  
Dry Cast 6" or 7" Wall

**3,600**  
POUNDS / INSERT

**6,500**  
POUNDS / INSERT

**LI-1095BR**  
Cam-LOK Insert  
Wet Cast 5" Wall

**3,000**  
POUNDS / INSERT

**4,500**  
POUNDS / INSERT

