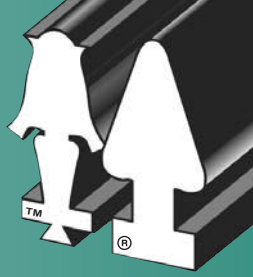




The Company with Connections<sup>®</sup>



CUSTOM MADE FIBERGLASS HOLDERS FOR CONNECTORS

# FIELD SLEEVES For Curved or Flat Wall Structures

## FIBERGLASS FIELD SLEEVES

An alternative method to cast a watertight connector into a concrete structure. They can be used in the plant or poured in place in the field. Each field sleeve is custom built to fit a particular structure that will fit any size of our connectors.



## CONNECTORS

Our field sleeves can be used with the following connectors:

- A-LOK Premium
- A-LOK X-CEL
- A-LOK STM
- Z•LOK
- Z-LOK STM
- Quik-LOK
- Septic Seals



Curved Wall Field Sleeve With A•LOK XCEL Connector



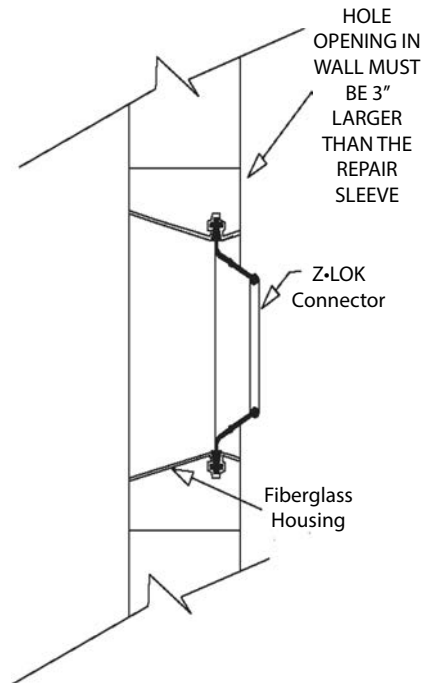
Z•LOK Mounted in Field Sleeve



Flat Wall Field Sleeve With A•LOK STM Connector

## FIELD SLEEVE INSTALLATION

Into an Opening in an Existing Round or Flat Wall Structure



### Step 1.

Check the A-LOK Premium, A-LOK X-CEL, or Z-LOK in the A-LOK Field Sleeve and pipe O.D. to make sure they are correct.

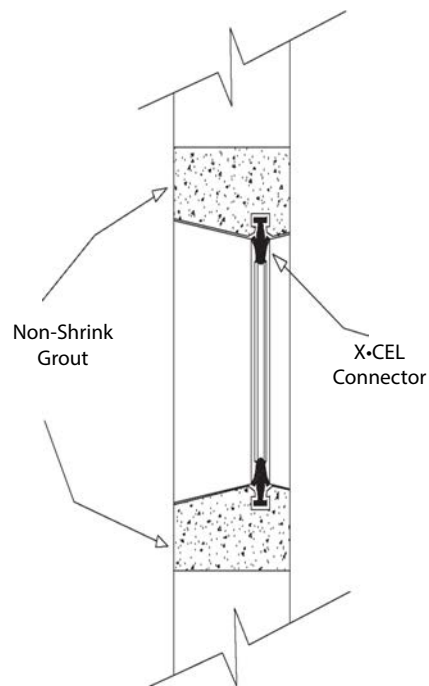
### Step 2.

Make a perimeter, on the structure, three (3) inches larger than the outside diameter of the A•LOK Field Sleeve.

### Step 3.

On this perimeter either:

- a.) Core the entire opening to create a hole.
- b.) Drill a series of one (1) inch or larger holes no more than 5 inches apart so a jackhammer can be used to create an opening for the Field Sleeve.



### Step 4.

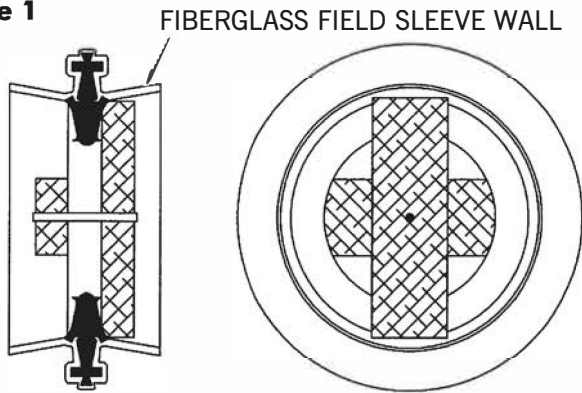
Set up A-LOK Field Sleeve in opening on correct grade. Pack annular space between opening and outside diameter of field sleeve firmly with non shrink grout. Carefully follow grout manufacturer's instructions for mixing, placing and curing.

### Step 5.

Once grout is cured, **review Pipe Installation Instructions for Z•LOK or A-LOK Connectors** on **side 2 of these instructions.**

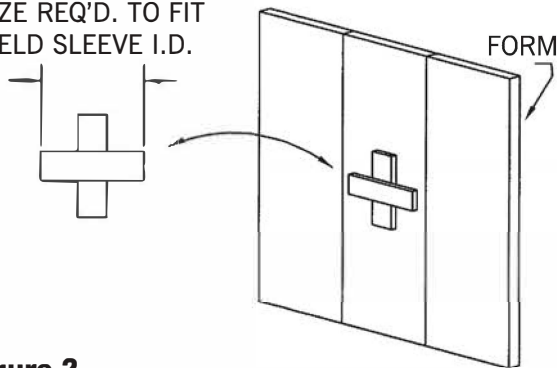
# POUR IN PLACE A-LOK FIELD SLEEVE INSTALLATION INSTRUCTIONS

**Figure 1**



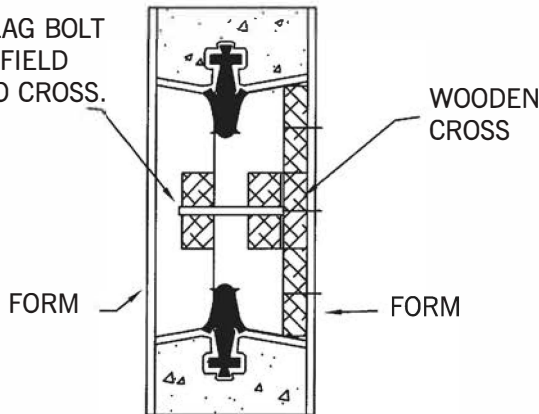
LARGER SIZE FIELD SLEEVE WITH STRUTS

SIZE REQ'D. TO FIT  
FIELD SLEEVE I.D.

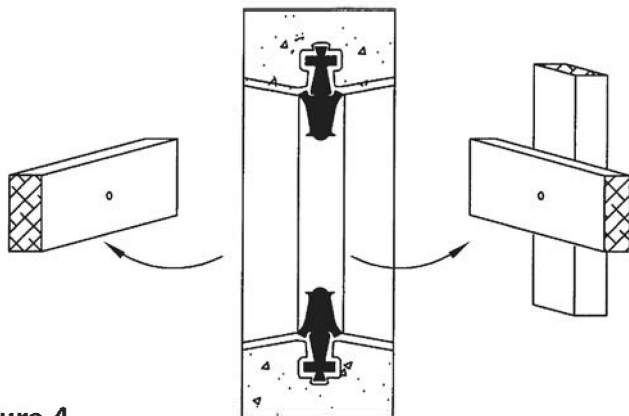


**Figure 2**

NAIL OR LAG BOLT  
HOLDING FIELD  
SLEEVE TO CROSS.



**Figure 3**



**Figure 4**

**STEP 1.**

A wooden cross must be built and fastened to the form work to secure the sleeve and prevent ovalation during the concrete pour. Cut 2 pieces of 2x4 as shown in Figure 2 to fit inside sleeve. Mark desired pipe location on form wall and nail or lag bolt cross to mark.

**STEP 2.**

Place sleeve on cross and secure remaining form work as shown in Figure 3.

On sizes over 15" use preinstalled struts to attach to form and position flat part of field sleeve on bottom towards outside of structure.

**STEP 3.**

Pour, cure and strip in normal fashion.

**STEP 4.**

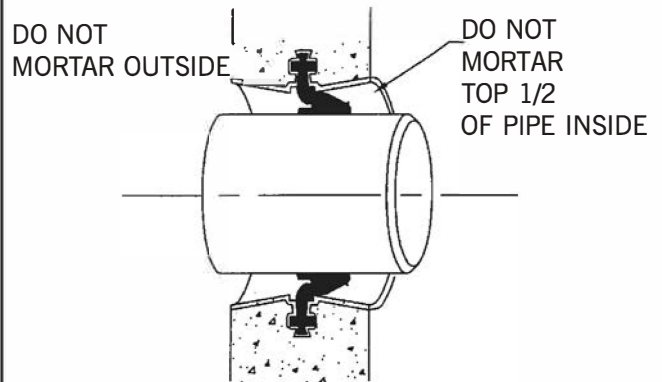
Remove all remaining wood inside field sleeve, Figure 4.

**STEP 5.**

Installed pipe, Figure 5.

## WARNING

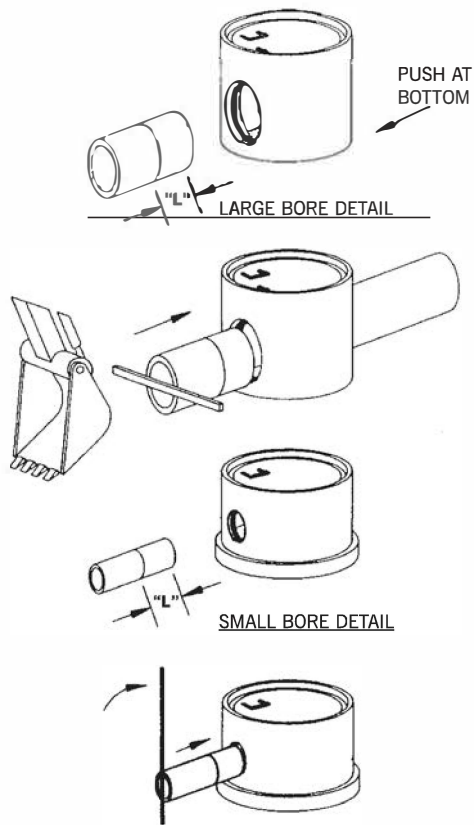
Because of the A-LOK connectors ability to insure a flexible, watertight joint, it is our strong recommendation that no mortar be placed around the connector at all on the outside of the structure and that no mortar be placed around the top half of the connector on the inside when completing the invert work. The use of mortar in either of these areas would eliminate the flexibility for which the connector is designed, and cause problems of shear.



**Figure 5**

PIPE INSTALLED IN A-LOK FIELD SLEEVE

# A-LOK CONNECTOR PIPE INSTALLATION INSTRUCTIONS



## STEP 1:

Confirm that pipe surface is smooth, clean and free of foreign materials, chips, gouges and form seams due to manufacturing or handling. Slightly bevel any sharp or blunt edges caused by the cutting of the pipe.

## STEP 2:

Lubricate the connector and the entire section of the pipe that will be inserted into the connector. The chart below lists A-LOK's minimum lubrication length "L".

PIPE SIZE	MIN. LUBRICATION LENGTH "L"
4" - 15"	12"
16" - 18"	18"
21" & Larger	24"

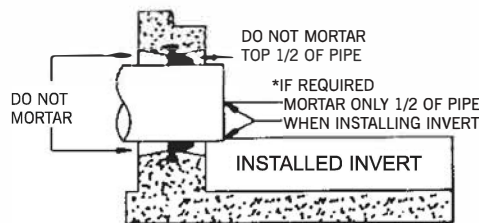
## STEP 3:

Center the pipe and insert the pipe into the connector using a bar or back hoe depending on the size. Once the pipe is coupled with the connector, deflect the structure or pipe to achieve the proper angle.

## WARNING:

To insure the A-LOK Connector remains a flexible watertight connector, it is A-LOK Products, Inc. strong recommendation that no mortar be placed between the pipe and wall of the concrete structure. The use of mortar in this area would decrease the effectiveness of the connector to compensate for shear caused by settlement or ground movement.

**NOTE:** To determine the sub-grade from the invert of the pipe, measure from the outside base of the structure to the junction of the connector and flat spot. Then add the wall thickness of the pipe plus 1/4 inch.



**CAUTION:** When installing pipe stubs for future pipeline installation, all stubs must be properly restrained to prevent any movement by means other than the A-LOK Connector.

# IMPORTANT Z-LOK CONNECTOR PIPE INSTALLATION INSTRUCTIONS

**STEP 1** Clean and lightly lubricate Z-LOK and all of pipe to be inserted in Z-LOK.

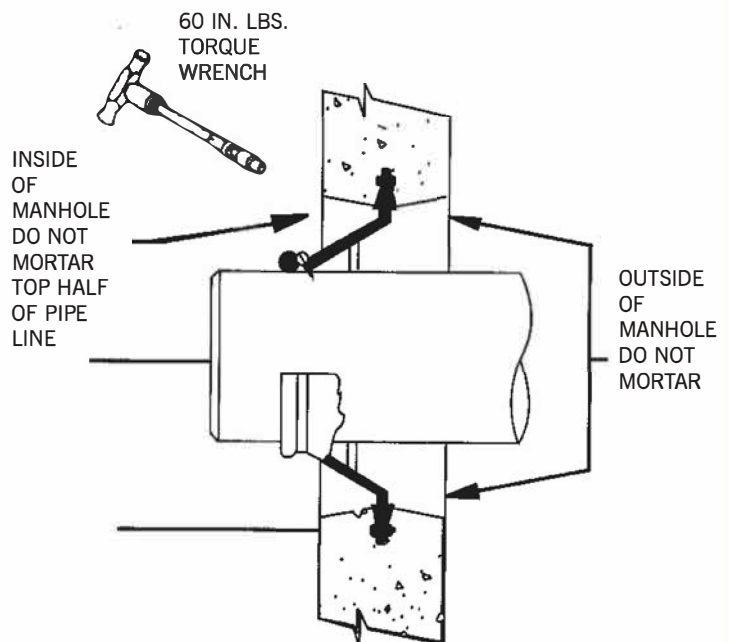
**STEP 2** If pipe is cut, care should be taken to allow no sharp edges. Bevel and lubricate lead end of pipe.

**STEP 3** Center pipe and insert.

**STEP 4** After inserting pipe, it is important to fasten stainless steel band with torque to 60 in. lbs. directly behind inner rubber "O" ring. This should be done prior to any annular deflection or backfilling takes place. Pipe bedding on outside of manhole is critical as non-rigid pipe may ovate if not bedded properly.

## WARNING

To insure the Z-LOK connector remains a flexible, watertight joint, it is our strong recommendation that no mortar be placed between the pipe and the wall of the precast concrete unit. The use of mortar in this area would eliminate the flexibility for which the connector was designed, and cause problems of shear.



## CAUTION

When installing pipe stubs for future pipeline, installation of all stubs should be properly restrained to prevent any movement.